



Model: [GM-485422](#) USB to RS-485/422
Commercial Interface Converter
Instruction Manual

Contents

1. Summary	3
2. Functions	3
3. Connector and Signal	3
4. Hardware Installation and Application	3
5. Communication Connection Chart	4
6. Problems and Troubleshooting	4

Summary

With the rapid development of the computer industry, USB technology is taking the place of various kinds of traditional low speed peripheral interfaces. However, RS-485 and RS-422 interface designs are still used in many facilities under current industrial environments; therefore, serial converters are used by many to implement the data transmission from the USB (Universal Serial Bus) of a computer to RS-485 and/or RS-422 equipments.



[GM-485422](#) is a universal USB to RS-485 or RS-422 converter that has no need for an external power supply. Compatible with USB, RS-422, and RS-485 standards, the GM-485422 is capable of performing the conversion from single-ended USB signal into balance differenced signal of RS-422 or RS-485. Quick state-of-the-art transient voltage suppressor (TVS) and discharge tubes are adopted to protect the RS-422 and RS-485 interfaces.

Under normal conditions the TVS tube is in the state of high resistance. However, when both ends of the TVS tube are hit by a transient high energy, the impedance at both ends can be depressed by the TVS at a very high speed. After absorbing a high current, the voltage between the two ends is suppressed and kept at a pre-set value; therefore no damage is caused to

the electrical components behind by the transient high voltage impact.

The electrical protection can effectively restrain lightning or ESD (electro static discharge) with a protection voltage of 600W on each line for lightning surge and surge voltage or transient over voltage possibly caused up by various reasons. At the same time, a high-speed transmission of RS-422 and/or RS-485 interfaces is ensured by the tiny capacitance between the poles.

RJ-45 and DB9 male connectors are used for connection from RS-422 and RS-485 to other pieces of equipment. The unique I/O circuit of the internal zero delay auto transceiver contained in the converter controls the data stream direction automatically without any handshaking signal (for example RTS, DTR etc).

The converter is plug-and-play without any jumper settings needed for mode shift between full duplex (RS-422) and half duplex (RS-485). All these features ensure a universal application on all the existing communication software and hardware interfaces.

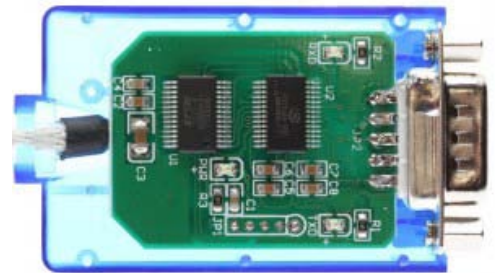

A reliable and stable point-to-point and point-to-multipoint communication can be ensured by [GM-485422](#) photoelectric isolation interface converter. For point-to-multipoint communication, as many as 32 interface facilities of RS-422 or RS-485 standard can be connected to each converter, and a high data transmission rate of 300-921.6Kbps can be achieved. Power indicator LED and data traffic indicator LED are also available with the converter for malfunction indication. Conversions from [USB to RS-422](#) and USB to RS-485 are supported.

Functions

1. Standards: conforming to USB V1.1 and 1.0, EIA RS-485 and RS-422, backwards compatible.
2. USB signals: VCC, DATA+, DATA-, GND, FG
3. RS-485 signals: T+, T-, and GND.
4. RS-422 signals: T+, T-, R+, R-, and GND.
5. Working modes: asynchronous, point-to-point or point-to-multipoint, 2-line half duplex and 4-line full duplex.
6. Direction control: adoption of automatic data stream control for automatic recognition and control of data transmission direction.
7. Baud rate: 300-921.6Kbps automatic detection of the transmission rate of the serial interface signal.
8. Workload ability: point-to-multipoint supported a maximum of 32 RS-422 or RS-485 interface equipments are supported.
9. Transmission distance: 1200 meters for RS-485/422 end (when 9,600bps) and a maximum of 5 meters for USB.
10. Interface protection: 600W lightning strike and surge protection and ± 5 KV electrostatic protection.
11. Interface forms: An interface female connector, RJ-45 and DB9 male connectors for USB end.
12. Signal indication: 3 indicator lights for Power (PWR), Send (TXD) and Receive (RXD).
13. Transmission media: twisted-pair cable or shielded cable.
14. Transmission rate: 921,600bps to 100M., 38,400bps to 600M, 9,600bps to 1200M.
15. Dimensions: 1555mm \times 36mm \times 16mm.
16. Working environment: -25°C to 70°C, relative humidity 5% to 95%.
17. Transmission distance: 0-1200 meters (921,600bps-9,600bps)
18. Supports Win98, 2000, 2003, 2008, XP, Vista, 7, 8, CE, Mac, Linux.

Connector and Signals

RS-485 and RS-422 output signals and PIN Assignment

DB9 connector (PIN)	Output Signal	RS-422 Full Duplex Cabling	RS-485 Half Duplex Cabling
1	T/R+	Sending (A+)	RS-485 (A+)
2	T/R-	Sending (B-)	RS-485 (B-)
3	RXD+	Receiving (A+)	Null
4	RXD-	Receiving (B-)	Null
5	GND	Grounding	Grounding
6	N/A		
7	N/A		
8	N/A		
9	N/A		

Hardware Installation and Application

Read the user manual carefully before installing the [GM-485422](#) interface converter. Put the signal cable of the equipment into the USB socket. The product adopts the universal connector of USB, DB-9 or RJ-45 for input and output interface with automatic mode shift RS-485 or RS-422 mode without jumper setting. Either twisted pair cable or shielded cable is applicable for easy installation or un-installation. T/R+/T/R- represents sending and receiving the A+/B-, RXD+/RXD- represents receiving the A+/B-, GND represents public underground line. Point-to-point and point-to-multipoint and half duplex communication use the two lines of T/R+ and T/R-, point-to-point and point-to-multipoint and full duplex communication use the four lines of T/R+, T/R-, RXD+ and RXD-.

[GM-485422](#) interface converter supports the following 4 communication modes:

1. Point-to-point 4-line full duplex
2. Point-to-multipoint 4-line full duplex
3. Point-to-point 2-line half duplex
4. Point-to-multipoint 2-line half duplex

In order to prevent the signal reflection or interference when converter is used in full-duplex or half-duplex mode, a proper matching resistance should be connected at the terminal of the line ($120\ \Omega$ $1/4W$).

Communication Connection Chart

USB to RS-422 Conversion

1. RS-422 point-to-point / 4-line full duplex

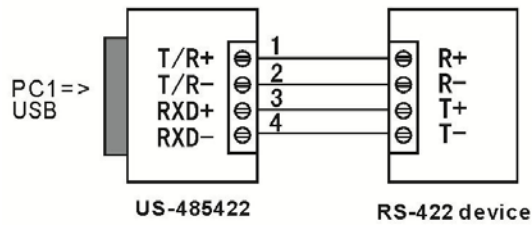

2. RS-422 point-to-point / 4-line full duplex

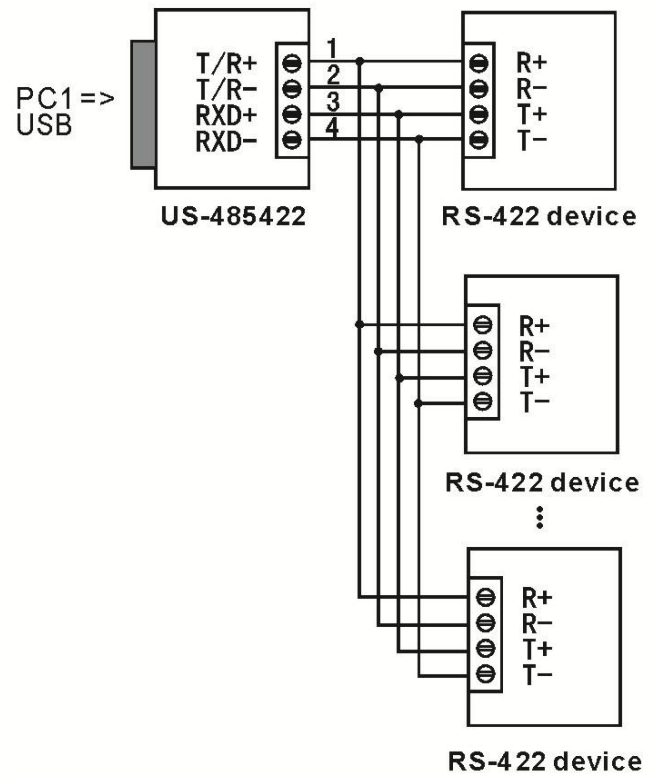

3. Full duplex connection between GM-485422 interface converters

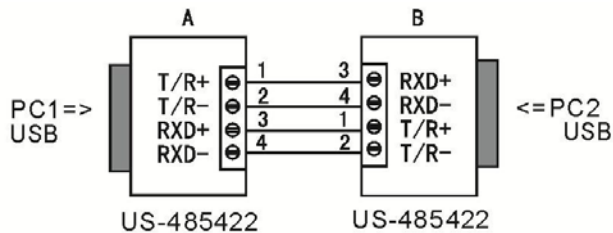

USB to RS-485 Conversion

1. RS-485 point-to-point / 2-line half duplex

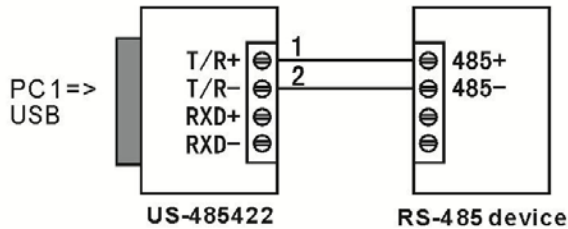

2. RS-485 point-to-multipoint / 2-line half duplex

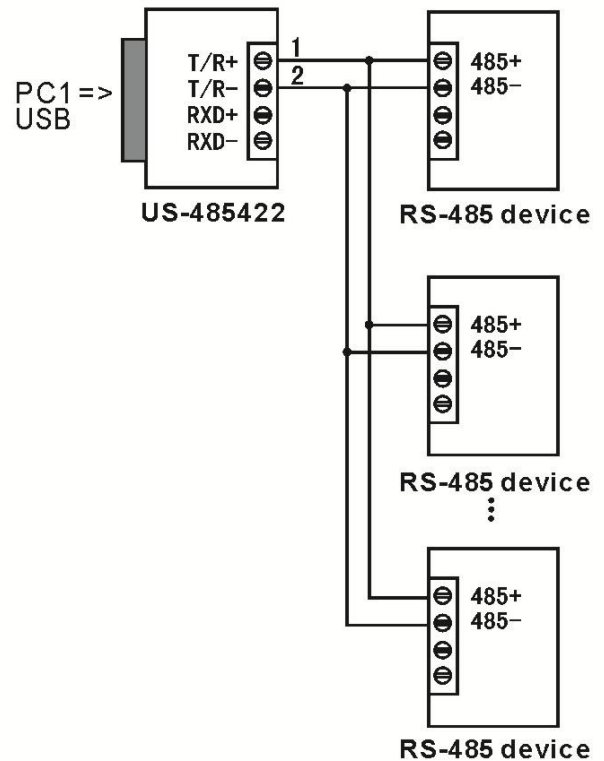

3. Half duplex connection between GM-485422 interface converters

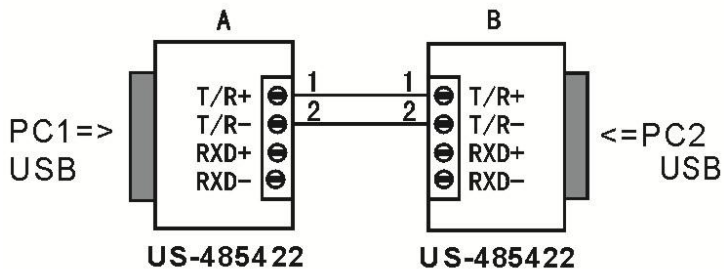

Problems and Troubleshooting

1. Data communication failure

- Check to make sure USB cable is OK.
- Make sure RS-485/RS-422 output interface cable is OK.
- Make sure power supply is OK.
- Make sure the wire terminal connection is OK.
- Make sure the indicator lights flash when receiving.
- Make sure the indicator lights flash when sending.

2. Data missing or incorrect

- Check to see whether the data rate and format at both ends of the communication equipment are consistent.