



Model: [US-422i](#) USB to RS-485/RS-422 Industrial
Photoelectric Isolation Interface Converter
Instruction Manual

Summary

With rapid development of computer industry, USB is taking the place of various kinds of traditional low speed peripheral interfaces. However, [RS-485 / RS-422 interface](#) designs are still used in many of the important facilities under current industrial environment; therefore, converter is used by many users to implement the data transmission from USB of a computer to RS-485/RS-422 equipments.

The [US-422I](#) is a universal USB / RS-485 / 422 converter. The US-422I has a built-in photo electrical isolator and DC/DC isolation module without external power supply needed. Compatible with USB, RS-422 and RS-485 standards, US-422I is capable to perform the conversion from single-ended USB signal into balance differenced signal of RS-422 or RS-485. The built-in photoelectric isolator can provide an isolation voltage of as high as 2,500Vrms. Quick state-of-the-art transient voltage suppressor (TVS) and discharge tube are adopted to protect the RS-422 / RS-485 interfaces.

Under normal conditions, the TVS tube is in the state of high resistance. However, when both ends of the TVS tube are hit by a transient high energy, the impedance at both ends can be depressed by the TVS at a very high speed, and after absorbing a high current, the voltage between the two ends is suppressed and kept at a pre-set value, therefore no damage is caused to the electrical components behind by the transient high voltage impact. The protector can effectively restrain lightning or ESD (Electrostatic Discharge) with a protection voltage of 1,500W on each line for lightning surge and surge voltage or transient over voltage possibly caused up by various reasons, and at the same time, a high-speed transmission of RS-422 / RS-485 interfaces is ensured by the tiny capacitance between the poles.

RJ-45 and DB9 male connectors are used for connection from RS-422 and RS-485 to other equipments. The unique I/O circuit of the internal zero delay auto transceiver contained in the converter controls the data stream direction automatically without any handshaking signal (for example RTS, DTR etc). The converter is plug-and-play without any jumper settings needed for mode shift between full duplex (RS-422) and half duplex (RS-485). All these features ensure a universal application on all the existing communication software and hardware interfaces.

A reliable and stable point-to-point and point-to-multipoint communication can be ensured by [US-422I](#) photoelectric isolation interface converter. For point-to-multipoint communication, as many as 128 interface facilities of RS-422 or RS-485 standard can be connected to each converter, and a high data transmission rate of 300-128,000bps can be achieved. Power indicator light and data traffic indicator light are also available with the converter for malfunction indication. Conversions from USB to RS-422 and USB to RS-485 are supported.

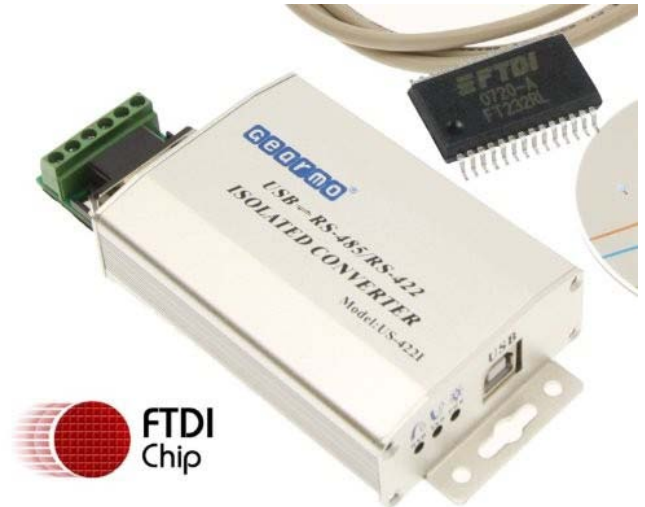

Functions

1. Standards: conforming to USB V1.1 and 1.0, EIA RS-485 and RS-422, backwards compatible.
2. USB signals: VCC, DATA+, DATA-, GND, FG
3. RS-485 signals: T+, T-, and GND.
4. RS-422 signals: T+, T-, R+, R-, and GND.
5. Working modes: asynchronous, point-to-point or point-to-multipoint, 2-line half duplex and 4-line full duplex.
6. Direction control: adoption of automatic data stream control for automatic recognition and control of data transmission direction.
7. Baud rate: 300-128,000bps, automatic detection of the transmission rate of the serial interface signal.
8. Workload ability: point-to-multipoint supported a maximum of 128 RS-422 or RS-485 interface equipments are supported.
9. Transmission distance: 5,000 meters for RS-485/422 end (when 9,600bps) and a maximum of 5 meters for USB.
10. Interface protection: 1,500W lightning strike and surge protection and $\pm 5\text{KV}$ electrostatic protection.
11. Interface forms: An interface female connector, RJ-45 and DB9 male connectors for USB end.
12. Signal indication: 3 indicator lights for Power (PWR), Send (TXD) and Receive (RXD).
13. Transmission media: twisted-pair cable or shielded cable.
14. Transmission rate: 128,000bps to 300M., 38,400bps to 2.4KM., 9,600bps to 5KM.
15. Dimensions: 96mm \times 64mm \times 26mm.
16. Working environment: -40°C to 85°C , relative humidity 5% to 95%.
17. Transmission distance: 0-5,000 meters (128,000bps-9,600bps)
18. Supports Win98, 2000, 2003, 2008, XP, Vista, 7, 8, CE, Mac, Linux.

Connector and Signals

RS-485, RS-422 Output Signals and PIN Assignment

DB9 connector (PIN)	RJ-45 (PIN)	Output Signal	RS-422 Full Duplex Cabling	RS-485 Half Duplex Cabling
1	5	T/R+	Sending (A+)	RS-485 (A+)
2	4	T/R-	Sending (B-)	RS-485 (B-)
3		RXD+	Receiving (A+)	Null
4		RXD-	Receiving (B-)	Null
5	2, 7	GND	Grounding	Grounding
6		N/A		
7		N/A		
8		N/A		
9		EARTH	Protective Grounding	Protective Grounding

PIN Assignment for RJ-45 Socket

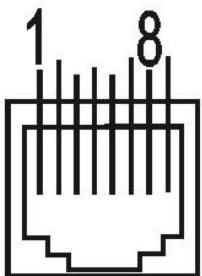

Hardware Installation and Application

Read the user manual carefully before installing the [US-422I](#) photoelectric isolation interface converter. Put the signal cable of the equipment into the USB socket. The product adopts the universal connector of USB, DB-9 or RJ-45 for input and output interface with automatic mode shift RS-485 or RS-422 mode without jumper setting. T/R+T/R- represents sending and receiving the A+/B-, RXD+/RXD- represents receiving the A+/B-, GND represents public underground line. Point-to-point and point-to-multipoint and half duplex communication use the two lines of T/R+ and T/R-, point-to-point and point-to-multipoint and full duplex communication use the four lines of T/R+, T/R-, RXD+ and RXD-.

US-422I interface converter supports the following 4 communication modes:

1. Point-to-point 4-line full duplex
2. Point-to-multipoint 4-line full duplex
3. Point-to-point 2-line half duplex
4. Point-to-multipoint 2-line half duplex

In order to prevent the signal reflection or interference when converter is used in full-duplex or half-duplex mode, a proper matching resistance should be connected at the terminal of the line ($120\ \Omega$ 1/4W).

Communication Connection Chart

USB to RS-422 Conversion

1. RS-422 point-to-point / 4-line full duplex

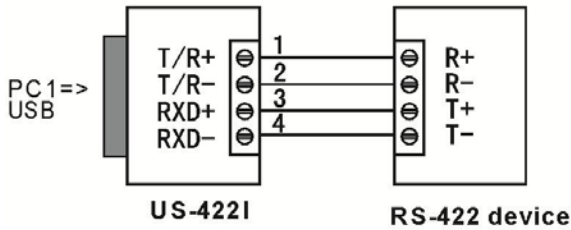

2. RS-422 point-to-multipoint / 4-line full duplex

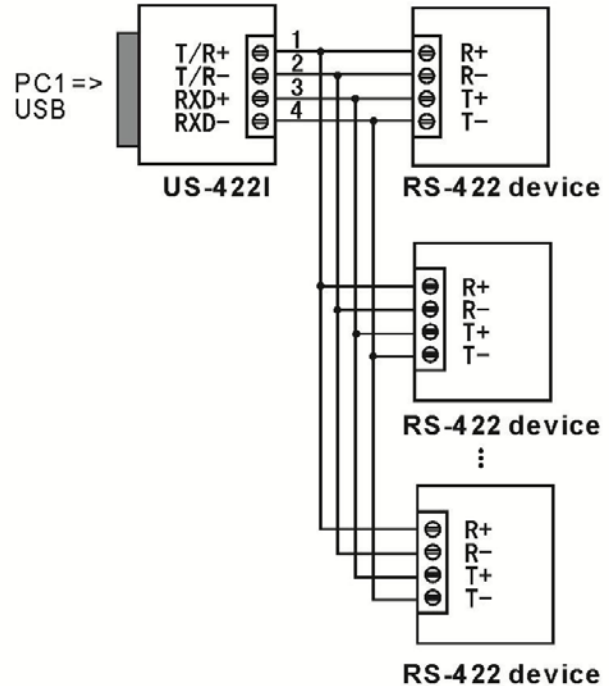

3. Full duplex connection between US-422I interface converters

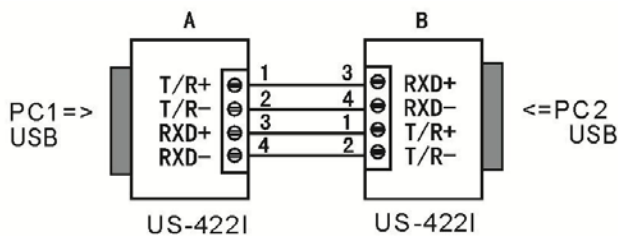

USB to RS-485 Conversion

1. RS-485 point-to-point / 2-line half duplex

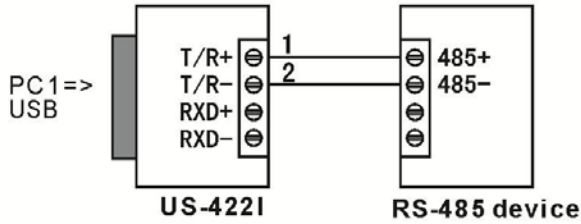

2. RS-485 point-to-multipoint / 2-line half duplex

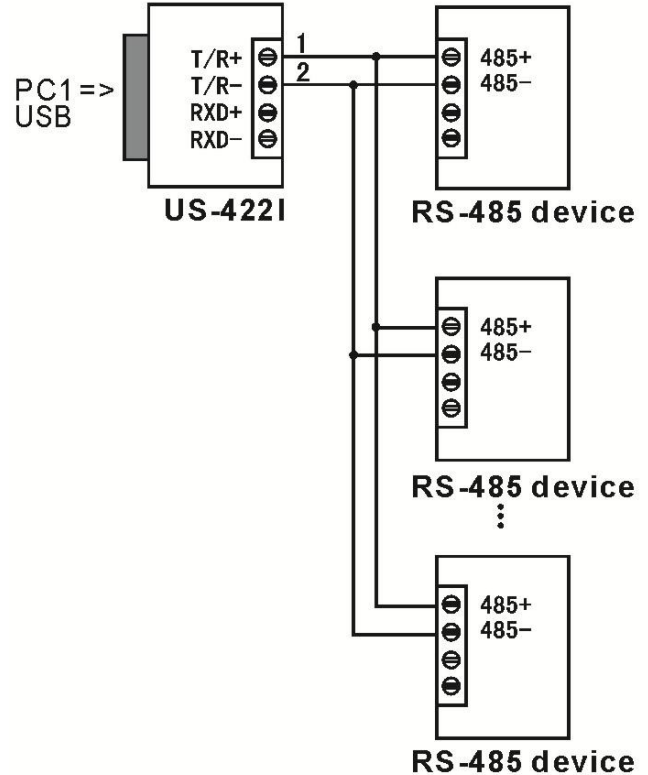

3. Half duplex connection between US-422I interface converters

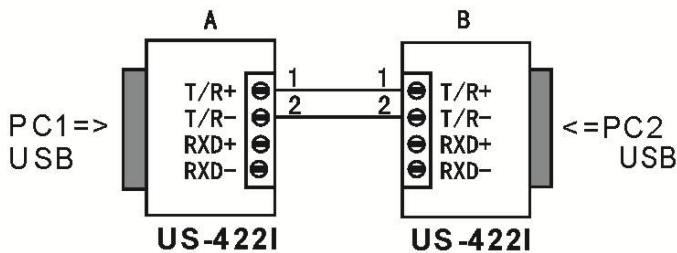

Connector and Signal

1. Data communication failure
 - a. Check to make sure USB cable is OK.
 - b. Make sure RS-485/RS-422 output interface cable is OK.
 - c. Make sure power supply is OK.
 - d. Make sure the wire terminal connection is OK.
 - e. Make sure the indicator lights flash when receiving.
 - f. Make sure the indicator lights flash when sending.
2. Data missing or incorrect
 - a. Check to see whether the data rate and format at both ends of the communication equipment are consistent.