



**gearmo®**

**User Manual**

# **RS-232 USB 2.0 Serial Adapter 12"**

**Model No. GM-FTDI-A12**

[gearmo.com](http://gearmo.com)

# Contents

---

- Summary .....	<b>1</b>
- Functions .....	<b>1</b>
- Hardware Installation & Application .....	<b>1</b>
- Performance Parameters .....	<b>2</b>
- Connector & Signal .....	<b>2</b>
- Product Dimensions & Connection Diagram .....	<b>3</b>
- USB to RS-232 Communication .....	<b>4</b>
- Faults & Troubleshooting .....	<b>4</b>

# Summary

---

- ▶ With rapid development of computer industry, USB is taking the place of various kinds of traditional low speed peripheral interfaces. However, RS-232 interface designs are still used in many of the important facilities under current industrial environment; therefore, converter is used by many users to implement the data transmission from USB of a computer to RS-232 equipments.
- ▶ [GM-FTDI-A12](#) is a universal USB/RS-232 interface converter. No external power supply needed. Compatible with USB and RS-232 standards, GM-FTDI-A12 is capable to perform the conversion from single-ended USB signal into UART signal of RS-232. DB9 male connectors are used for connection from RS-232 interface. The unique I/O circuit of the internal zero delay auto transceiver contained in the converter controls the data stream direction automatically. The converter is plug-and-play. All these features ensure a universal application on all the existing communication software and hardware interfaces.
- ▶ The data communication rate can be as high as 300-921.6Kbps by the point-to-point communication by [GM-FTDI-A12](#) interface. Power indicator light and data traffic indicator light are also available with the converter for malfunction indication. Conversion from USB to RS-232 is supported.

# Functions

---

[GM-FTDI-A12](#) interface converter supports the following communication mode:

1. Point-to-point communication mode.

# Hardware Installation & Application

---

Read the user manual carefully before installing the [GM-FTDI-A12](#) interface converter. Put the signal cable of the equipment into the USB socket. USB/DB9 male connectors are adopted for input/output interface connection for this product.

# Performance Parameters

1. Standards: Conforming to USB V1.1, 1.0 and 2.0 and EIA RS-232.
2. USB signals: VCC, DATA+, DATA-, GND, FG
3. RS-232 signals: DCD, RXD, TXD, DTR, GND, DSR, RTS, CTS, RI
4. Working mode: Asynchronous point-to-point mode.
5. Direction control: Adoption of automatic data stream control for automatic recognition and control of data transmission direction.
6. Baud rate: 300-921.6Kbps, automatically detection of the transmission rate of the serial interface signal.
7. Transmission Distance: 5 Meters for RS-232 and less than 5 Meters for USB.
8. Interface Protection: +-15KV electrostatic protection.
9. Interface Forms: B interface female connector and DB9 male connector for USB.
10. Signal Indication: 9 indicator lights for Power (PWR), Send (TXD), and Receive (RXD).
11. Transmission media: twisted-pair cable or shielded cable.
12. Dimensions: 304.8mm x 36mm x 16mm
13. Working environment: -40°C to 85°C, relative humidity of 5% to 95%
14. Supports Win98, 2000, 2003, 2008, XP, Vista, 7, 8, CE, Mac, Linux.

## Connector & Signals

### 1. Pin assignment of RS-232C

DB9M (PIN)	RS-232C
1	Data Carrier Detect (DCD)
2	Receive Data SIN (RXD)
3	Transmit Data SOUT (TXD)
4	Data Terminal Ready (DTR)
5	Signal Ground (GND)
6	Data Set Ready (DSR)
7	Request to Send (RTS)
8	Clear to Send (CTS)
9	Ring Indicator (RI)

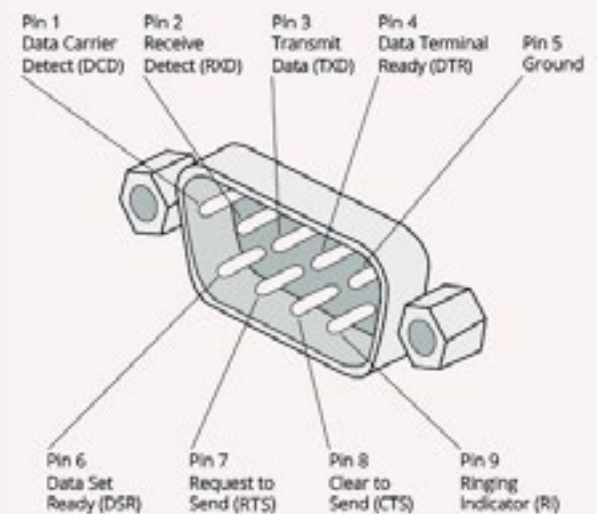

## 1. USB-A type: USB signal input and pin assignment

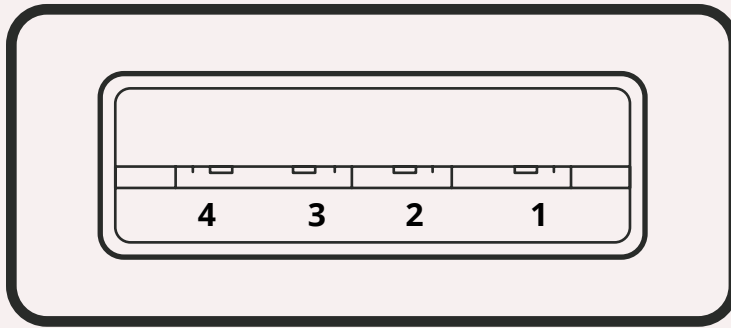

1. VCC
2. DATA-(DM)
3. DATA+(DP)
4. GND

## Product Dimension & Connection Diagram

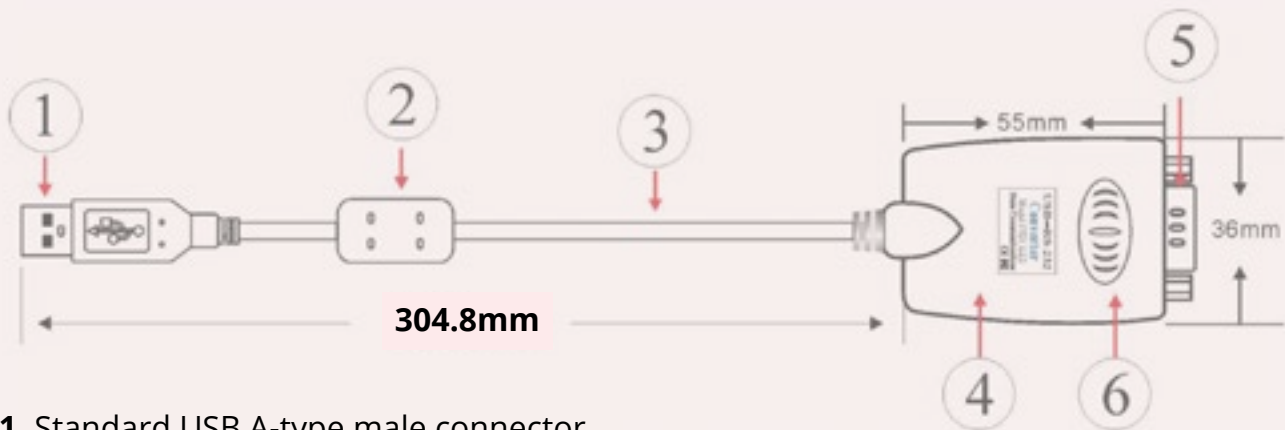

1. Standard USB A-type male connector
2. Filter magnetic ring
3. Transparent and shielded standard 2.0 communication line
4. Fine shell (blue)
5. Standard DB9 male connector
6. MCU adopts the product of the British FTDI company

# USB to RS-232 Communication

---

1. DCD 2, RXD 3, TXD 4, DTR 5, GND 6, DSR 7, RTS 8, CTS 9, RI

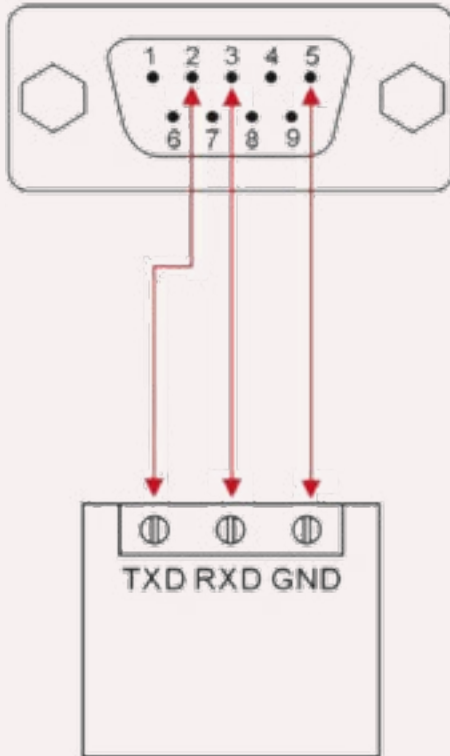

RS-232 Device

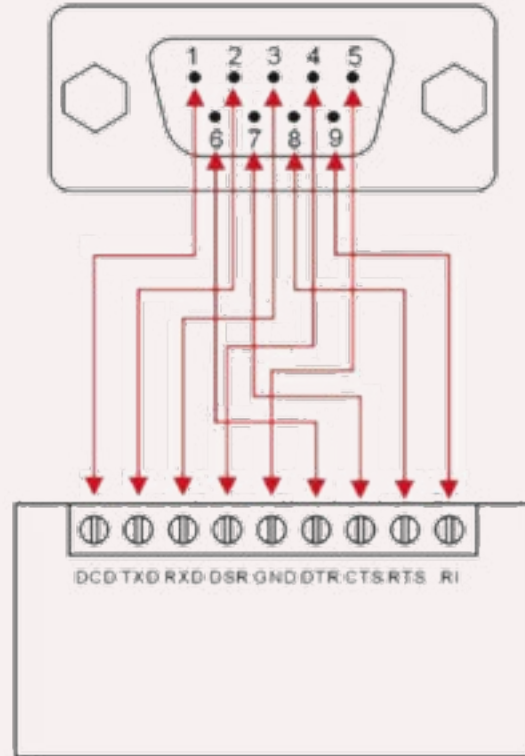

RS-232 Device

## Faults & Troubleshooting

---

### 1. Data Communication Failure

- Check the USB cable connection
- Make sure that the RS-232 output interface connection is correct
- Check the power supply
- Check the wire terminal connection
- Check receive indicator and see if it flashes
- Check send indicator and see if it flashes

### 2. Data missing or incorrect

- Check to see whether the data rate and format at both ends of the communication equipment is consistent.