



gearmo[®]

User Manual

**2-Port RS-232 USB 2.0 Serial Adapter
w/ LED Indicators Model No. GM-FTDI2X**

gearmo.com

Contents

- Summary	1
- Functions	1
- Hardware Installation & Application	1
- Performance Parameters	2
- Connector & Signal	2
- Product Dimensions & Connection Diagram	3
- USB to RS-232 Communication	4
- Faults & Troubleshooting	4

Summary

- ▶ The USB interface is gradually replacing the old-fashioned, low-speed peripheral interfaces with the continuous development of the PC industry. Many vital devices in current industrial environments are still designed using an RS-232 interface, so the USB to RS-232 converters are needed to transfer data between PC and RS-232 devices.
- ▶ [GM-FTDI2X](#) is a universal USB 2 port RS-232 converter which doesn't need external power supply and is compatible with USB and RS-232 standards. It can convert single-end USB signal to RS-232 signal, and it has built-in automatic transmit-receive switch without time delay. The unique I/O circuit can be used to automatically control the direction of data flow so as to make it plug-and-play and applicable to all existing communication software and interface hardware
- ▶ [GM-FTDI2X](#) supports point-to-point communication with data rate of 300-921,600bps. The power indicator and data traffic indicator LED's can be used for fault indication. USB to RS-232 conversion is supported.

Functions

[GM-FTDI2X](#) interface converter supports the following communication mode:

1. Point-to-point communication mode.

Hardware Installation & Application

Read the user manual carefully before installing the [GM-FTDI2X](#) interface converter. Put the signal cable of the equipment into the USB socket. USB/DB9 male connectors are adopted for input/output interface connection for this product.

Performance Parameters

1. Standards: Conforming to USB V1.1, 1.0 and 2.0 and EIA RS-232.
2. USB signals: VCC, DATA+, DATA-, GND, FG
3. RS-232 signals: DCD, RXD, TXD, DTR, GND, DSR, RTS, CTS, RI
4. Working mode: Asynchronous point-to-point mode.
5. Direction control: Adoption of automatic data stream control for automatic recognition and control of data transmission direction.
6. Baud rate: 300-921.6Kbps, automatically detection of the transmission rate of the serial interface signal.
7. Transmission Distance: 5 Meters for RS-232 and less than 5 Meters for USB.
8. Interface Protection: +-15KV electrostatic protection.
9. Interface Forms: B interface female connector and DB9 male connector for USB.
10. Signal Indication: 9 indicator lights for Power (PWR), Send (TXD), and Receive (RXD).
11. Transmission media: twisted-pair cable or shielded cable.
12. Dimensions: 1500mm x 36mm x 16mm
13. Working environment: -40°C to 85°C, relative humidity of 5% to 95%
14. Supports Win98, 2000, 2003, 2008, XP, Vista, 7, 8, CE, Mac, Linux.

Connector & Signals

1. Pin assignment of RS-232C

DB9M (PIN)	RS-232C
1	Data Carrier Detect (DCD)
2	Receive Data SIN (RXD)
3	Transmit Data SOUT (TXD)
4	Data Terminal Ready (DTR)
5	Signal Ground (GND)
6	Data Set Ready (DSR)
7	Request to Send (RTS)
8	Clear to Send (CTS)
9	Ring Indicator (RI)

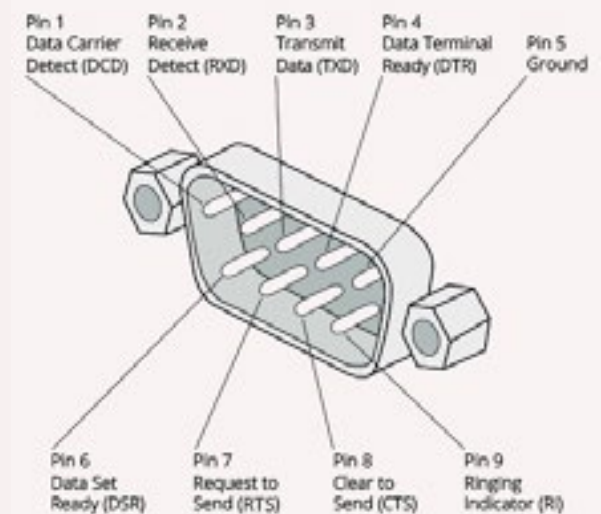

1. USB-A type: USB signal input and pin assignment

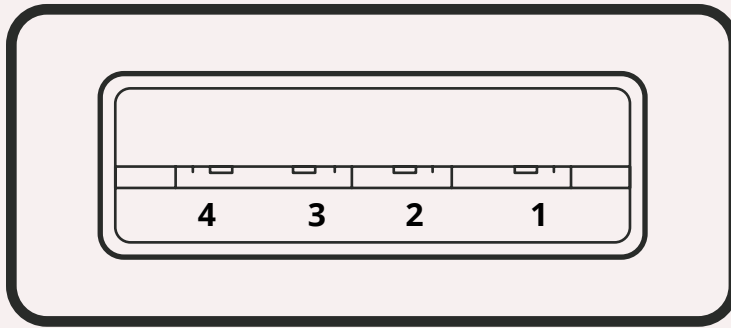

1. VCC
2. DATA-(DM)
3. DATA+(DP)
4. GND

Product Dimension & Connection Diagram

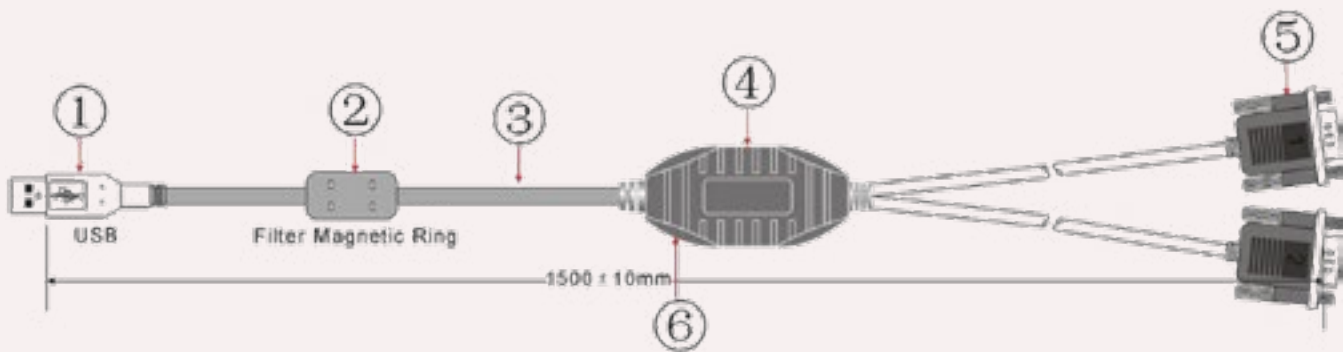

1. Standard USB A-type male connector
2. Filter magnetic ring
3. Screened black standard USB 2.0 cable
4. Aesthetic shell (black)
5. Standard DB9 male connector
6. Master chip of FTDI company in England

USB to RS-232 Communication

1. DCD 2, RXD 3, TXD 4, DTR 5, GND 6, DSR 7, RTS 8, CTS 9, RI

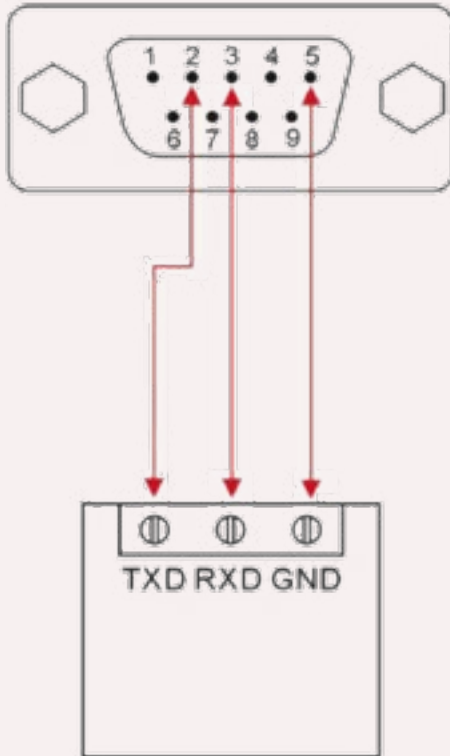

RS-232 Device

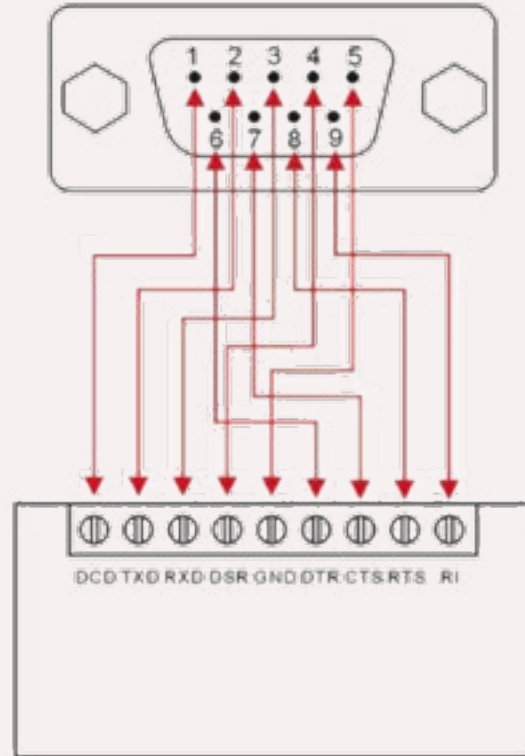

RS-232 Device

Faults & Troubleshooting

1. Data Communication Failure

- Check the USB cable connection
- Make sure that the RS-232 output interface connection is correct
- Check the power supply
- Check the wire terminal connection
- Check receive indicator and see if it flashes
- Check send indicator and see if it flashes

2. Data missing or incorrect

- Check to see whether the data rate and format at both ends of the communication equipment is consistent.