



gearmo[®]

User Manual

RS-232 USB-C Serial Adapter

w/ LED Indicators Model No. GM-FTDI2-LED-C

gearmo.com

Contents

- Summary	1
- Functions	1
- Hardware Installation & Application	1
- Performance Parameters	2
- Connector & Signal	2
- Product Dimensions & Connection Diagram	3
- USB to RS-232 Communication	4
- Faults & Troubleshooting	4

Summary

▶ This USB serial device is a USB-C to RS-232 serial adapter compliant with USB 2.0 specifications, used to easily add a serial port to your computer even if they are unequipped with COM port ability.

▶ When connection activity is present, the LED's will flash letting you know you have signal on the pins. The [GM-FTDI2-LED-C](#) offers an advanced an FTDI Chipset supported by Windows 10. The device is powered individually by the USB 2.0 Type-C port and is easy to install with Plug & Play, it easily tests RS-232 Host to Device link with backward compatibility with USB Spec 1.1.

Functions

[GM-FTDI2-LED-C](#) interface converter supports the following communication mode:

1. Point-to-point communication mode.

Hardware Installation & Application

Read the user manual carefully before installing the [GM-FTDI2-LED-C](#) interface converter. Put the signal cable of the equipment into the USB socket. USB/DB9 male connectors are adopted for input/output interface connection for this product.

Performance Parameters

1. Standards: Conforming to USB V1.1, 1.0 and 2.0 and EIA RS-232.
2. USB Type-C reversible connector
3. RS-232 signals: DCD, RXD, TXD, DTR, GND, DSR, RTS, CTS, RI
4. Working mode: Asynchronous point-to-point mode.
5. Direction control: Adoption of automatic data stream control for automatic recognition and control of data transmission direction.
6. Baud rate: 300-921.6Kbps, automatically detection of the transmission rate of the serial interface signal.
7. Transmission Distance: 5 Meters for RS-232 and less than 5 Meters for USB.
8. Interface Protection: +-15KV electrostatic protection.
9. Interface Forms: B interface female connector and DB9 male connector for USB.
10. Signal Indication: 9 indicator lights for Power (PWR), Send (TXD), and Receive (RXD).
11. Transmission media: twisted-pair cable or shielded cable.
12. Dimensions: 914.4mm x 36mm x 16mm
13. Working environment: -40°C to 85°C, relative humidity of 5% to 95%
14. Supports Windows 7, 8, and Windows 10, Linux, Mac OS 10.X

Connector & Signals

1. Pin assignment of RS-232C

DB9M (PIN)	RS-232C	LED Color
1	Data Carrier Detect (DCD)	Green
2	Receive Data SIN (RXD)	None
3	Transmit Data SOUT (TXD)	Green
4	Data Terminal Ready (DTR)	Green
5	Signal Ground (GND)	Red
6	Data Set Ready (DSR)	None
7	Request to Send (RTS)	Green
8	Clear to Send (CTS)	None
9	Ring Indicator (RI)	None



Product Dimension & Connection Diagram

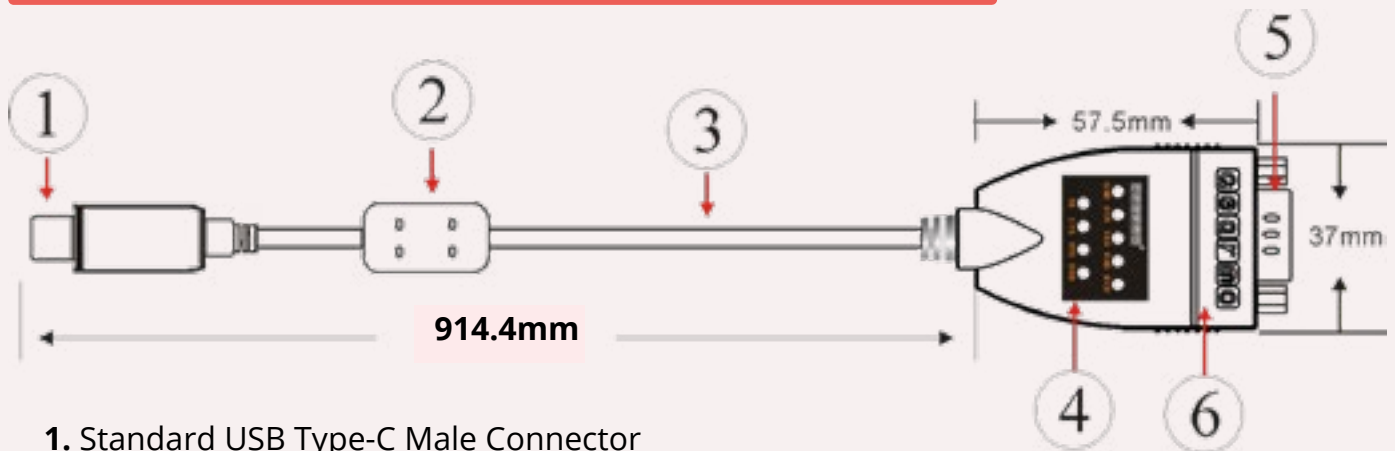

1. Standard USB Type-C Male Connector
2. Filter magnetic ring
3. Transparent and shielded standard 2.0 communication line
4. Fine shell (black)
5. Standard DB9 male connector
6. MCU adopts the product of the British FTDI company

USB to RS-232 Communication

1. DCD 2, RXD 3, TXD 4, DTR 5, GND 6, DSR 7, RTS 8, CTS 9, RI

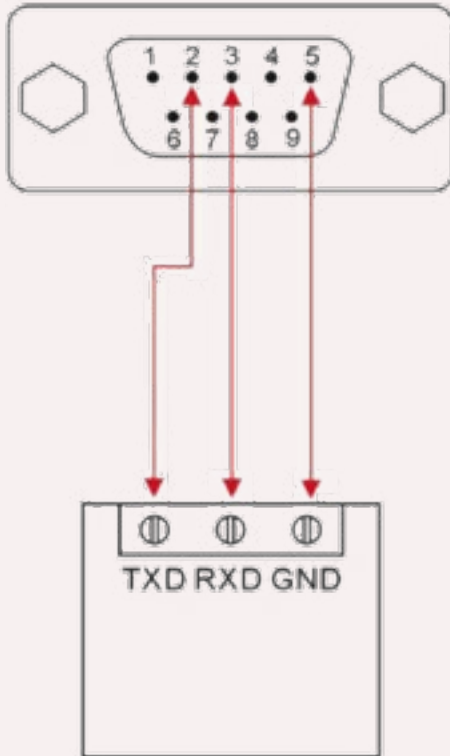

RS-232 Device

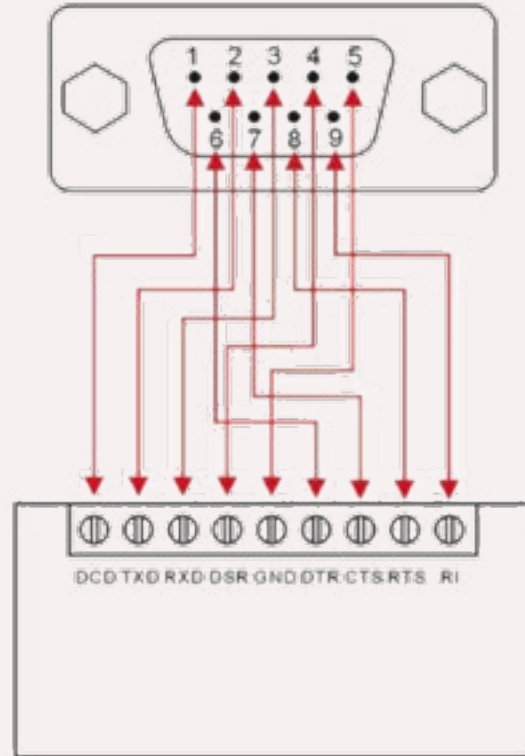

RS-232 Device

Faults & Troubleshooting

1. Data Communication Failure

- Check the USB cable connection
- Make sure that the RS-232 output interface connection is correct
- Check the power supply
- Check the wire terminal connection
- Check receive indicator and see if it flashes
- Check send indicator and see if it flashes

2. Data missing or incorrect

- Check to see whether the data rate and format at both ends of the communication equipment is consistent.